



Rewarding Learning

ADVANCED

General Certificate of Education
2022

Centre Number

--	--	--	--	--

Candidate Number

--	--	--	--

Physics

Assessment Unit A2 2

assessing

Fields, Capacitors and
Particle Physics

MV24

[APH21]

FRIDAY 10 JUNE, MORNING

Time

2 hours, plus your additional time allowance.

Instructions to Candidates

Write your Centre Number and Candidate Number in the spaces provided at the top of this page.

You must answer the questions in the spaces provided.

Do not write on blank pages.

Complete in black ink only.

Answer **all nine** questions.

Information for Candidates

The total mark for this paper is 100.

Quality of written communication will be assessed in question **7(a)**.

Figures in brackets printed at the end of each question indicate the marks awarded to each question or part question.

Your attention is drawn to the Data and Formulae Sheet which is inside this question paper.

You may use an electronic calculator.

Blank Page

(Questions start overleaf)

- 1 **Fig. 1.1** shows a wire carrying a current of 1.4A into the plane of the page.

Fig. 1.1

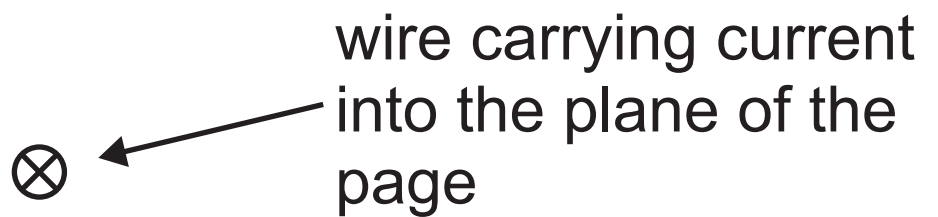

(a) (i) On **Fig. 1.1**, sketch the magnetic field that is produced around the wire due to the current. [3 marks]

(ii) The wire is placed between two magnetic poles as shown in **Fig. 1.2**. Draw an arrow to show the direction of the force on the current carrying wire produced by the two magnetic poles. [1 mark]

Fig. 1.2



(b) Calculate the magnetic field strength due to the magnetic poles if the force on the wire is $5.6 \times 10^{-3} \text{ N}$ and the length of wire in the magnetic field is 3.0 cm.
[3 marks]

Magnetic field strength = _____ T

Blank Page

(Questions continue overleaf)

2 **Fig. 2.1** shows a positively charged oil drop held stationary between two parallel horizontal plates X and Y. The plates are 0.025 m apart with a potential difference between them of 5.5 kV. The mass of the oil drop is 1.79×10^{-14} kg.

Fig. 2.1

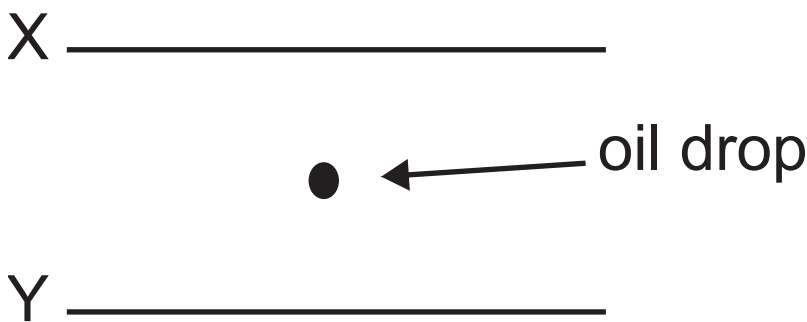

(a) Which plate is positively charged?
Explain your answer. [4 marks]

(b) (i) Calculate the charge on the oil drop and the number of electrons that were removed from the oil drop when it was charged. [6 marks]

Charge on oil drop = _____ C

Number of electrons removed = _____

(ii) Describe and explain what would happen to the oil drop if it gained an electron. [3 marks]

- 3 Four positive point charges of $2\ \mu\text{C}$ are placed at the corners of a square of sides $0.04\ \text{m}$. Another positive point charge of $3\ \mu\text{C}$ is placed in the centre of the square as shown in **Fig. 3.1**.

Fig. 3.1

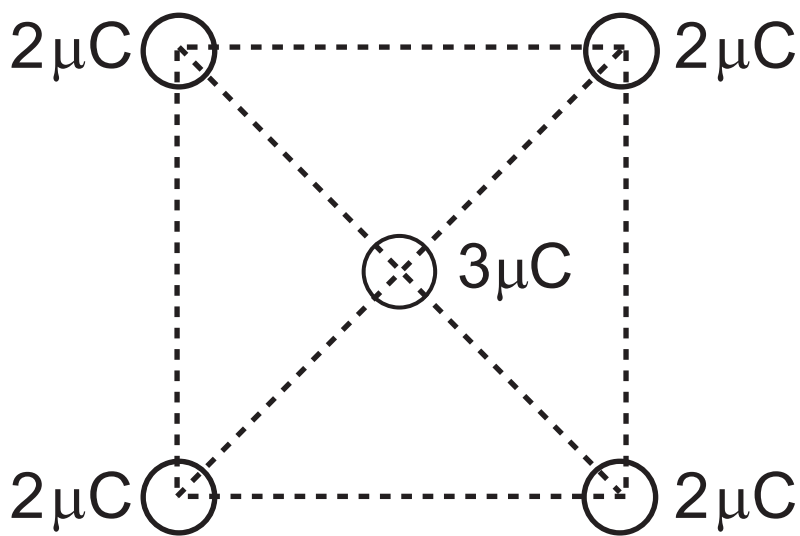

- (a) State the magnitude of the resultant force on the $3\ \mu\text{C}$ charge and explain your answer. [2 marks]

(b) One of the $2\mu\text{C}$ charges is removed as shown in **Fig. 3.2**.

Fig. 3.2

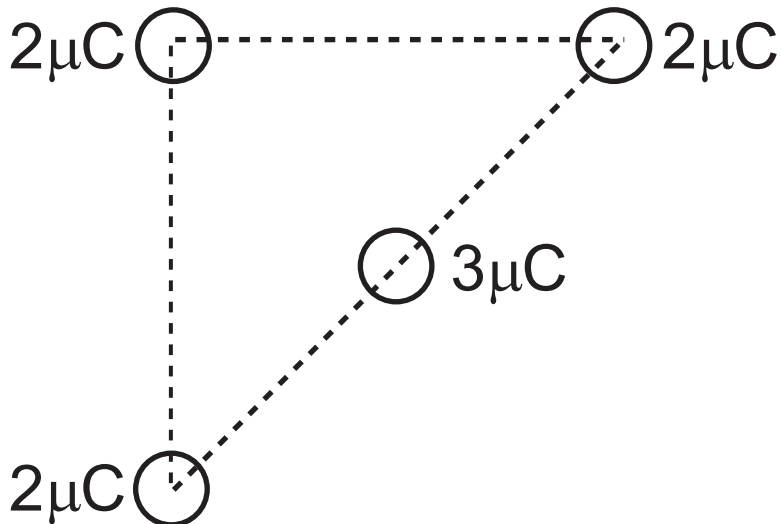

(i) Draw an arrow on **Fig. 3.2** to show the direction of the resultant force on the $3\mu\text{C}$ charge. [1 mark]

(ii) Calculate the resultant force acting on the $3\ \mu\text{C}$ charge. [5 marks]

Force = _____ N

4 (a) State Kepler's third law of planetary motion. [2 marks]

(b) Two of Jupiter's natural satellites are Io and Europa. Io's orbit has a radius of 4.22×10^8 m and a period of 1.53×10^5 s. Europa's orbit has a radius of 6.71×10^8 m.

(i) Calculate the period of Europa's orbit. [4 marks]

Period = _____ s

(ii) There is a point between Jupiter and Europa where the gravitational field strength is zero. This point is at a distance of 6.68×10^8 m from the centre of Jupiter. The mass of Jupiter is 1.90×10^{27} kg. Calculate the mass of Europa. [3 marks]

Mass = _____ kg

5 (a) An object with charge q moves through a magnetic field and follows a circular path of radius R .

(i) If the magnetic field strength is B , show that the momentum p of the object is given by **Equation 5.1**.
[3 marks]

$$p = qBR \qquad \text{Equation 5.1}$$

(ii) Cosmic rays are sub-atomic particles arriving from outer space. Most cosmic rays are protons travelling close to the speed of light. The magnetic field strength of our galaxy is 1×10^{-10} T.

If the momentum of the proton is less than a critical value, it drifts in circles within the galaxy, but if the momentum exceeds this critical value, the proton will escape the galaxy.

If the radius of the galaxy is 5×10^{21} m, calculate the critical value of the momentum of the proton. [2 marks]

Momentum = _____ kg m s⁻¹

(b) Explain why the speed of a proton could not be calculated correctly using the momentum calculated in part **(a)(ii)** and the mass of a proton from the data sheet.
[2 marks]

Blank Page

(Questions continue overleaf)

6 (a) A capacitor network is shown in Fig. 6.1.

Fig. 6.1

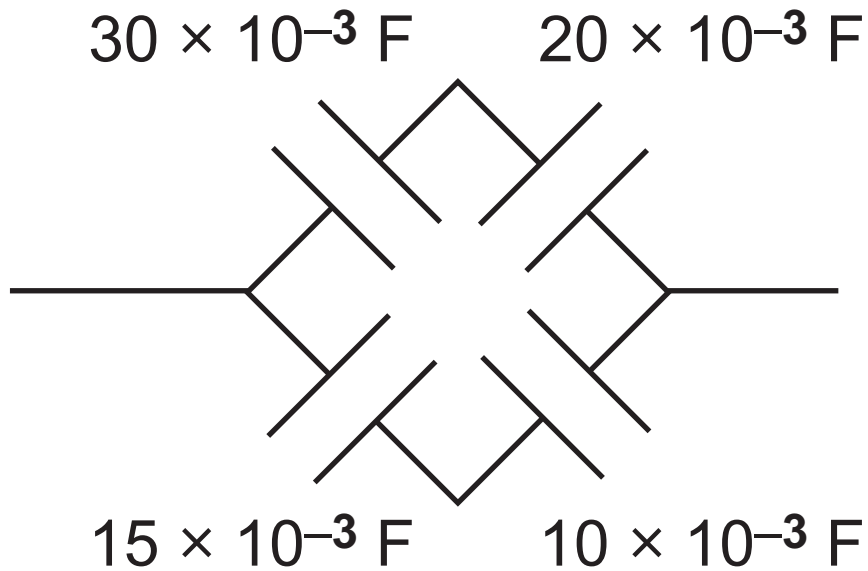

Show that the total capacitance of the network is $18 \times 10^{-3} \text{ F}$. [4 marks]

(b) The capacitor network is charged by connecting it to a 12 V supply.

(i) Calculate the charge stored in the network. [3 marks]

Charge = _____ C

(ii) Calculate the energy stored on the network. [3 marks]

Energy stored = _____ J

(c) The capacitor network is then disconnected from the 12 V supply and discharged through the network of resistors shown in **Fig. 6.2**.

Fig. 6.2

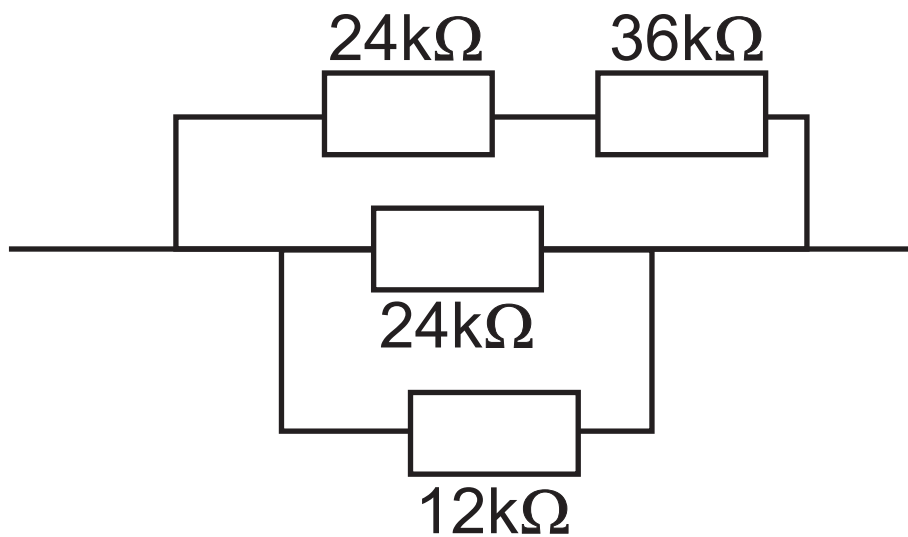

(i) Calculate the initial discharge current.
[4 marks]

Current = _____ A

- (ii) Use the axes of **Fig. 6.3** to sketch a graph to show how the discharge current will vary with time.
[2 marks]

Fig. 6.3

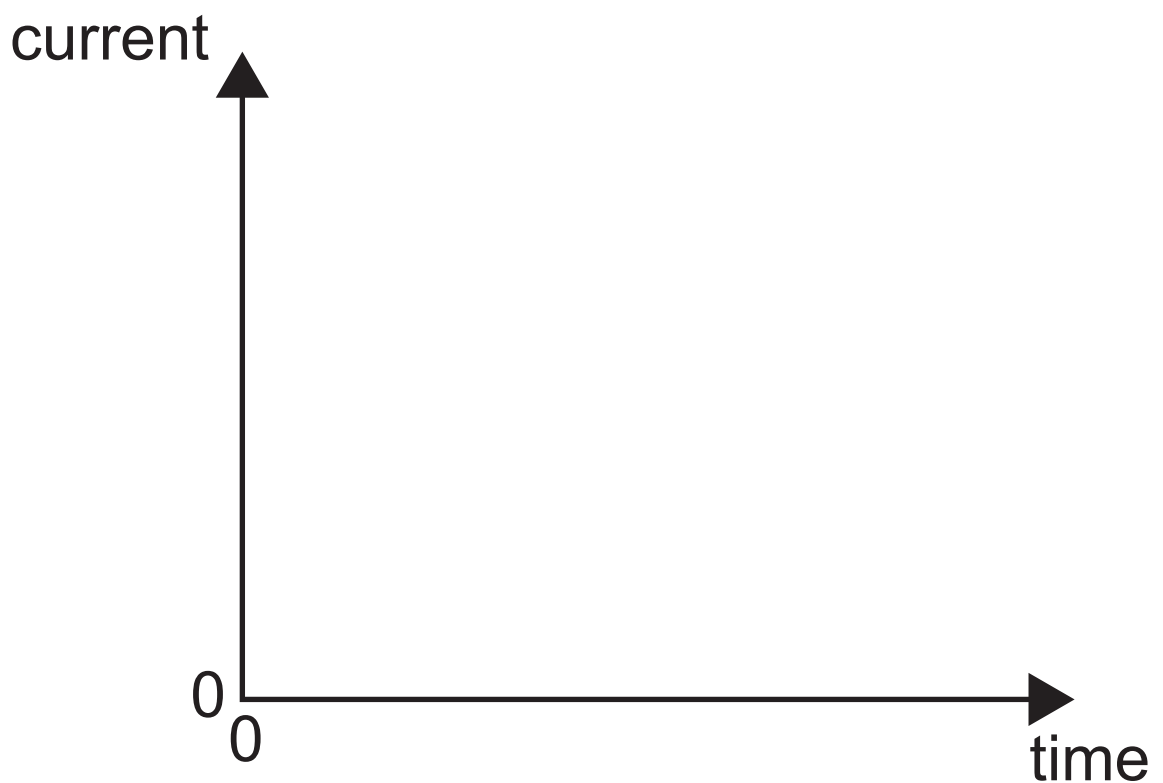

7 Quality of written communication will be assessed in part (a) of this question.

In an electric guitar, the energy of the vibrations of the steel guitar string are converted into an electrical signal by a device called a pick-up. A picture and a simplified diagram of a pick-up are shown in Fig. 7.1(a) and (b).

Fig. 7.1(a)

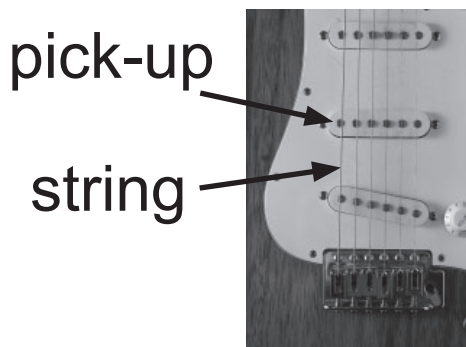
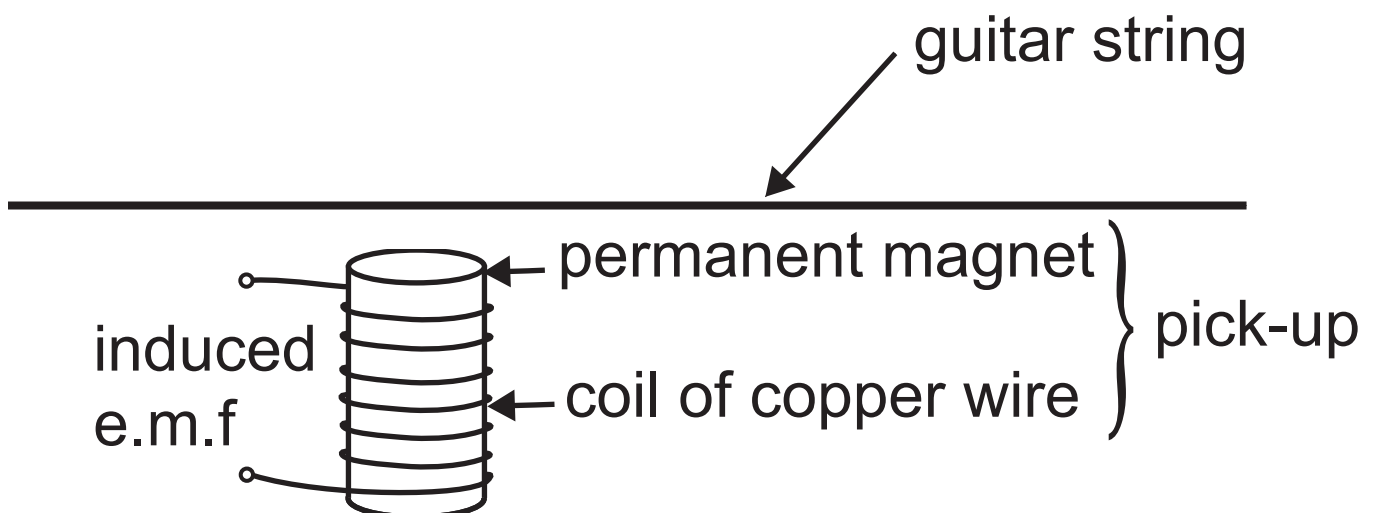

Fig. 7.1(b)



(a) Explain how, when the string vibrates in a direction perpendicular to the plane of the page, it causes an e.m.f. to be induced across the coil of wire.

State Faraday's law and use it to explain how plucking the string with greater force increases the e.m.f. [6 marks]

- (b) (i)** The length of a guitar string is 0.73 m and it is plucked at the centre, setting up a standing wave in the first mode of vibration. Draw the standing wave on the string shown in **Fig. 7.2**.
[1 mark]

Fig. 7.2

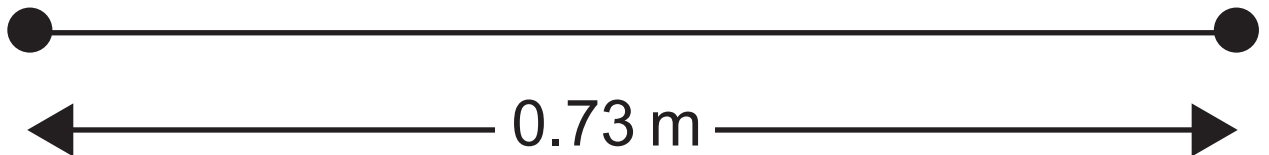

- (ii)** The speed of the wave is 286 m s^{-1} . Calculate the frequency of the note produced by the string. [3 marks]

Frequency _____ Hz

(iii) State how, and explain why, the frequency changes when the length of the string that vibrates is effectively shortened by holding it down along its length. [3 marks]

8 **Fig. 8.1** opposite shows how the output e.m.f. E of an a.c. generator varies with time.

(a) Use data from **Fig. 8.1** to determine the value of the constant ω in **Equation 8.1**. State the unit of ω .
[4 marks]

$$E = BAN\omega \sin\omega t \qquad \text{Equation 8.1}$$

$$\omega = \underline{\hspace{10cm}}$$

$$\text{Unit of } \omega = \underline{\hspace{10cm}}$$

Fig. 8.1

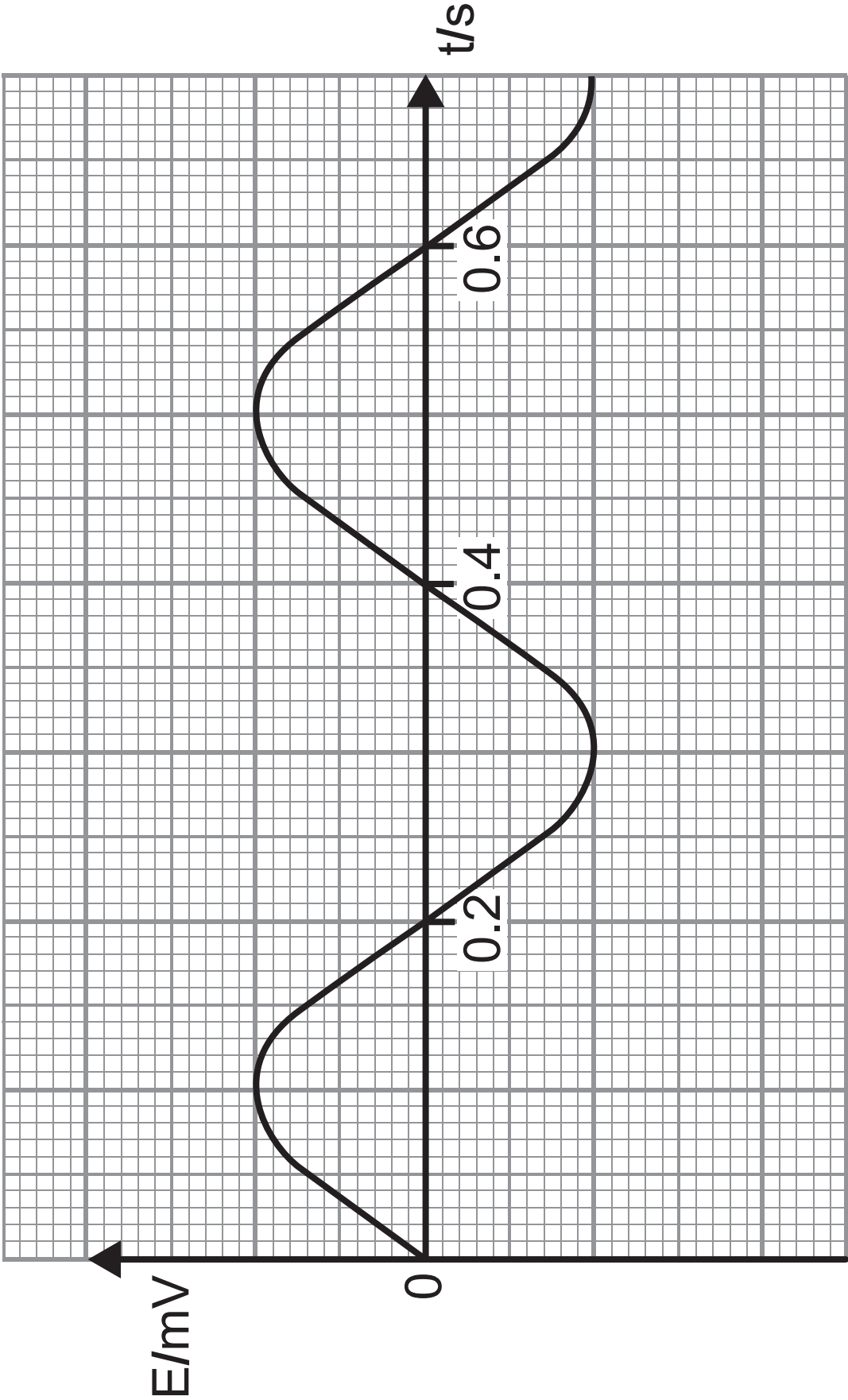

(b) The coil in a second a.c. generator has the same area as the first and twice the number of turns. It is rotated in a magnetic field of one quarter of the strength of the first generator. The coils in both generators are rotated at the same speed.

On **Fig. 8.1**, draw a line to show the output of the second generator.
[2 marks]

(c) On the axis drawn in **Fig. 8.2**, sketch a graph to show how the e.m.f. E generated would change over time t if a generator gradually slowed down.
[2 marks]

Fig. 8.2



9 Particle physicists use the unit GeV/c^2 as an appropriate unit of mass, where c is the speed of light.

(a) (i) Use the base units of GeV and the base units for c , the speed of light, to show that the unit GeV/c^2 is equivalent to the unit of mass, the kilogram. [3 marks]

(ii) A kaon K^+ is a positively charged meson with a rest mass of $0.494 \text{ GeV}/c^2$. Calculate the rest mass of a kaon in kg. [4 marks]

Rest mass = _____ kg

(b) (i) In particle physics, particles are classified according to their composition. Describe the composition of a kaon. [2 marks]

(ii) The four fundamental forces are shown below.
Tick the box beside each force that is experienced by the K^+ particle.
[2 marks]

Gravitational force

Electromagnetic force

Strong nuclear force

Weak nuclear force

(iii) A moving kaon decays at point X into two particles with the same magnitude of charge and velocity.

Fig. 9.1 shows the paths followed by the two particles due to a magnetic field which acts perpendicular to the plane of the page.

Fig. 9.1

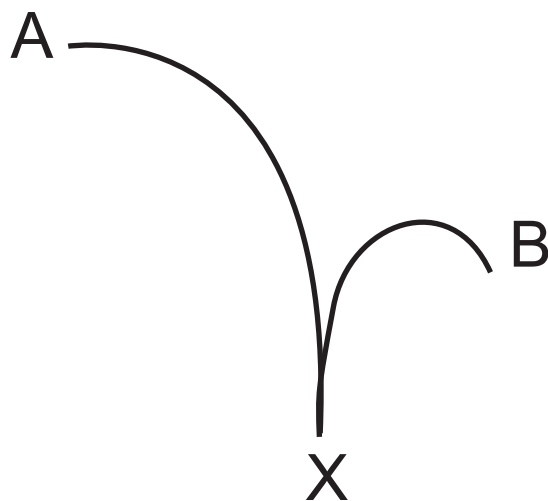

From **Fig. 9.1**, what conclusions can be made about the two particles which follow paths A and B?

[3 marks]

(c) (i) Explain what is meant by annihilation.
[2 marks]

(ii) Calculate the frequency of the electromagnetic radiation produced when an electron and positron annihilate. [3 marks]

Frequency = _____ Hz

This is the end of the question paper

SOURCES

Fig.7.1(a) Source: © *Getty Images*

For Examiner's use only	
Question Number	Marks
1	
2	
3	
4	
5	
6	
7	
8	
9	

Total Marks	
--------------------	--

Examiner Number

Permission to reproduce all copyright material has been applied for.
In some cases, efforts to contact copyright holders may have been unsuccessful and CCEA will be happy to rectify any omissions of acknowledgement in future if notified.